

Investigating the effect of reducing time to diagnosis for COVID-19 in Illinois

Reese Richardson, Manuela Runge, Tobias Holden, Jaline Gerardin

June 18, 2020



Institute for Global Health
Northwestern

What is the impact of finding mild symptomatic cases sooner?

- After a positive test is confirmed, patients are more likely to self-quarantine and less likely to engage in behaviors that put others at risk of infection
- Reducing the time between symptom onset and notification of positive test is of high interest. This includes reducing the time to testing and reducing the test turnaround time
- We use a spatial compartmental model of COVID-19 transmission, calibrated to COVID-19 hospitalization and death data across Illinois, to quantify the impact of reducing the **time to diagnosis**: number of days between symptom onset and notification of positive test

In our epidemiological model, the population of Illinois is assigned to compartments which each patient progresses through over time

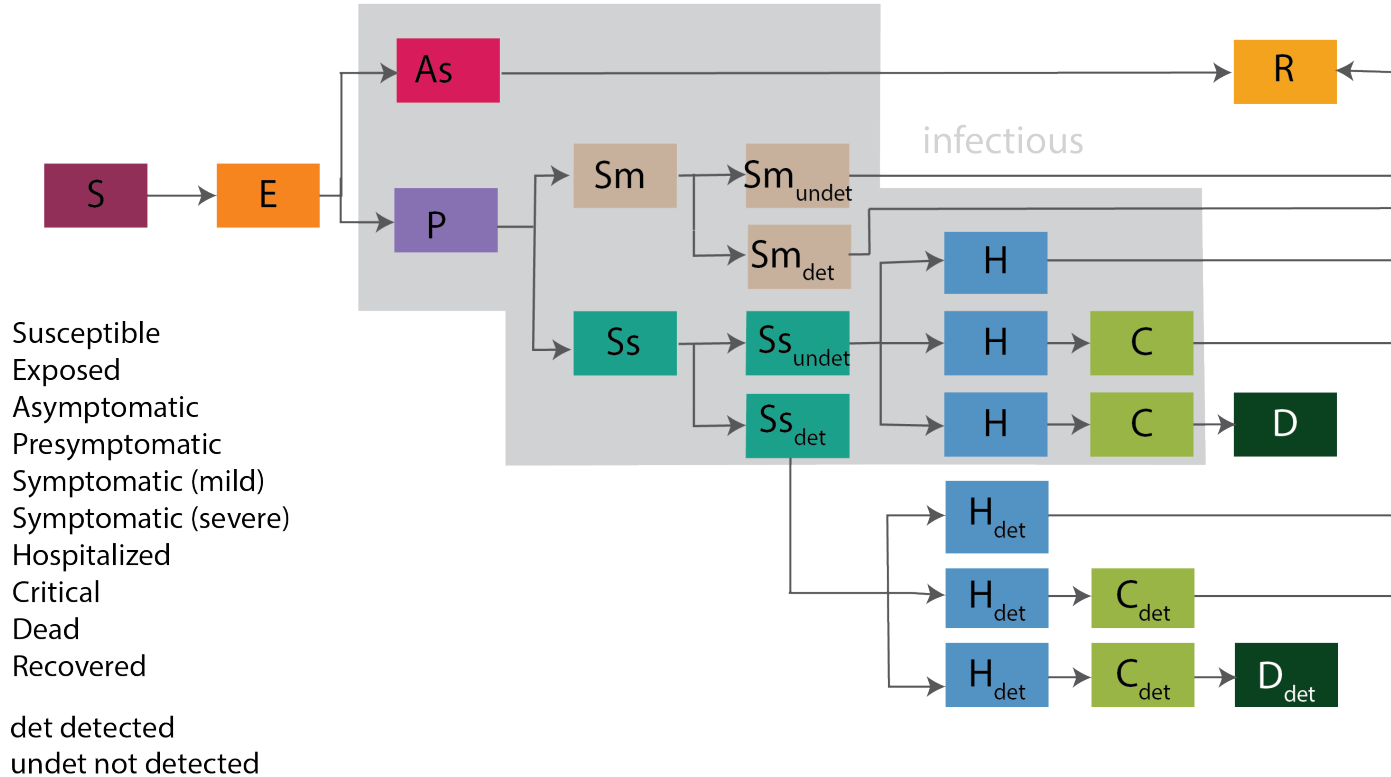

Each exposed patient who becomes mildly symptomatic spends some period of time in a compartment when they are still infectious, but haven't been tested or haven't received the results of their test

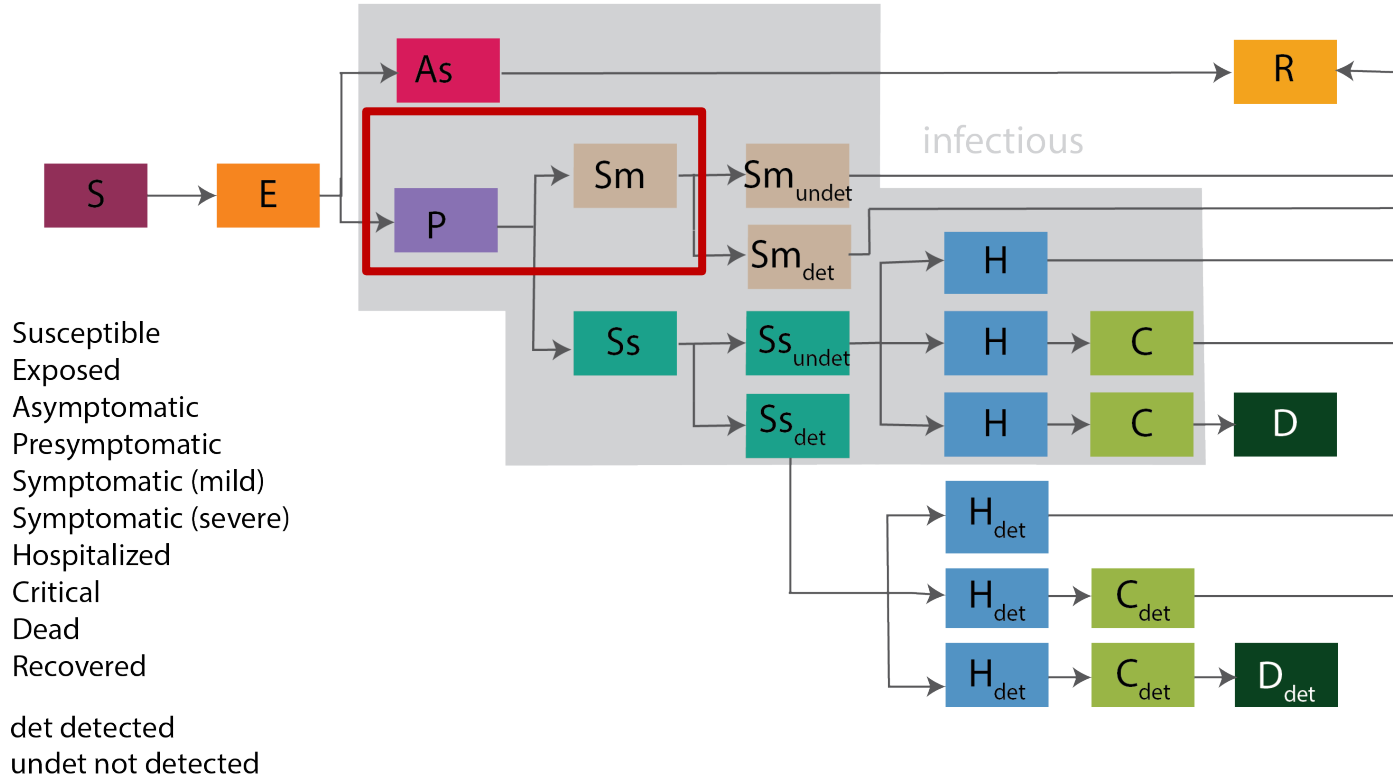

Once a mildly symptomatic patient receives a positive test, they are still infectious but their infectivity is reduced by 70-100%

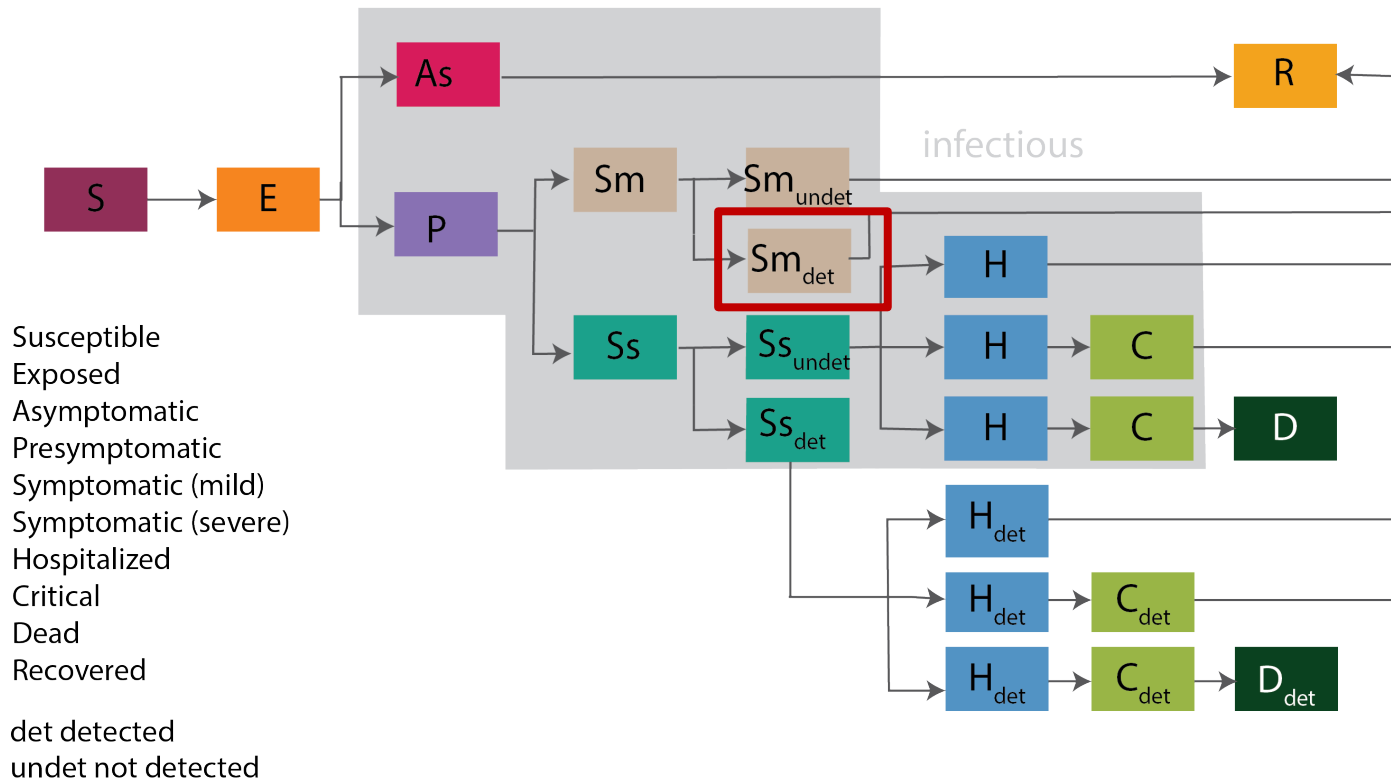

Model assumptions and simulations

- We assume a fixed symptomatic period of 9 days and a detection rate of 45% for mild symptomatic cases. The fraction that develops mild symptoms ranges from 45 to 63 %. The time to detection of severe cases was fixed to 2 days
- The model includes ~30 parameters that are sampled from uniform distributions. From these distributions 30 samples were drawn per value of time to diagnosis
- The simulations were run for each EMS region. Transmission intensity and lockdown effectiveness were fitted to hospitalization and death data.

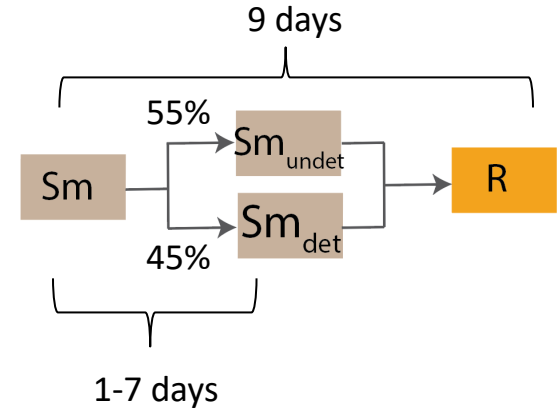

Framework for considering reductions in time to diagnosis

- We fix the time to diagnosis to **7 days** for the epidemic to date
- On June 15, time to diagnosis is reduced to a value between **2 days** and **7 days**
- For different values of time to diagnosis, we compare the **cumulative number of deaths** up to February 17, 2021
- In the background, we assume transmission conditions from early June continue indefinitely

All other factors being the same, reducing time to diagnosis reduces cumulative deaths

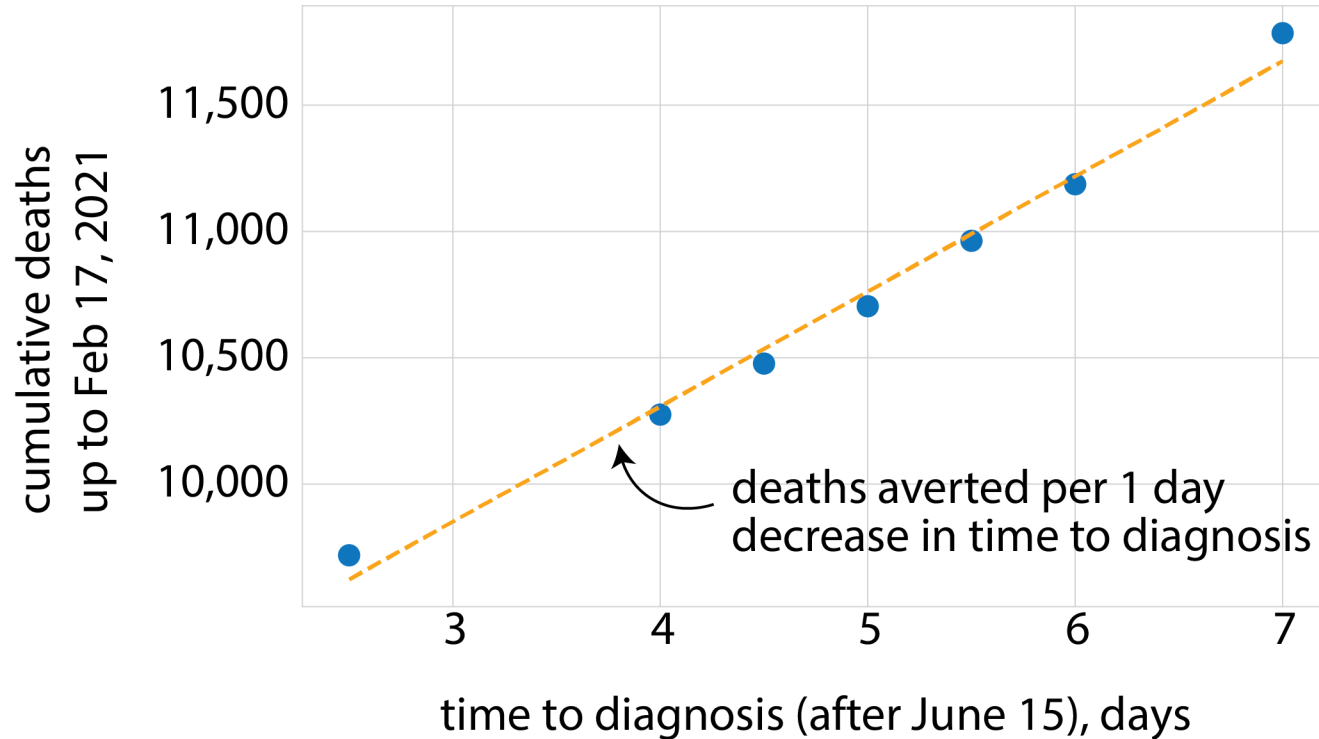

We quantify the relationship between reduction in time to diagnosis and deaths averted across multiple sampled parameter sets

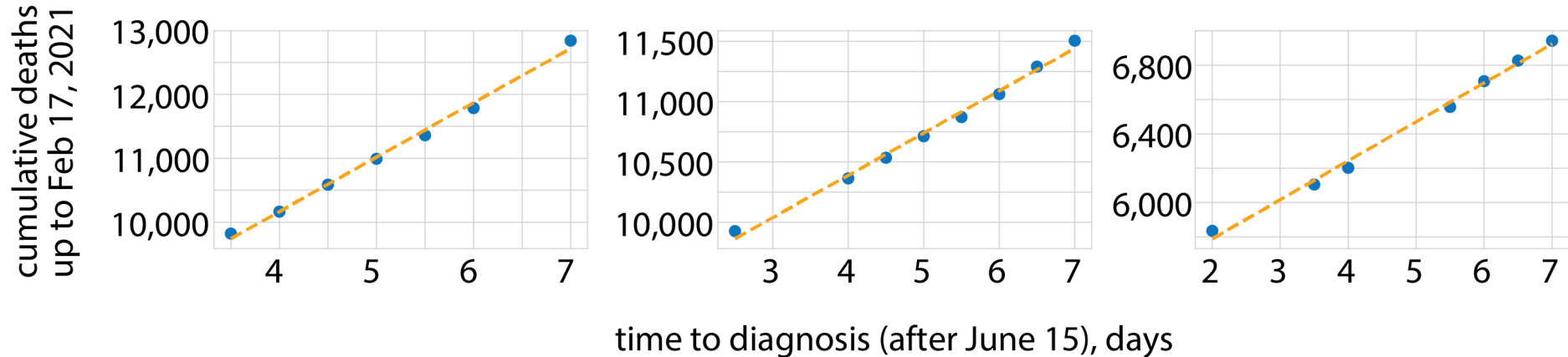

For a reduction made on June 15, on average **511** deaths were averted for each day of decrease in time to diagnosis

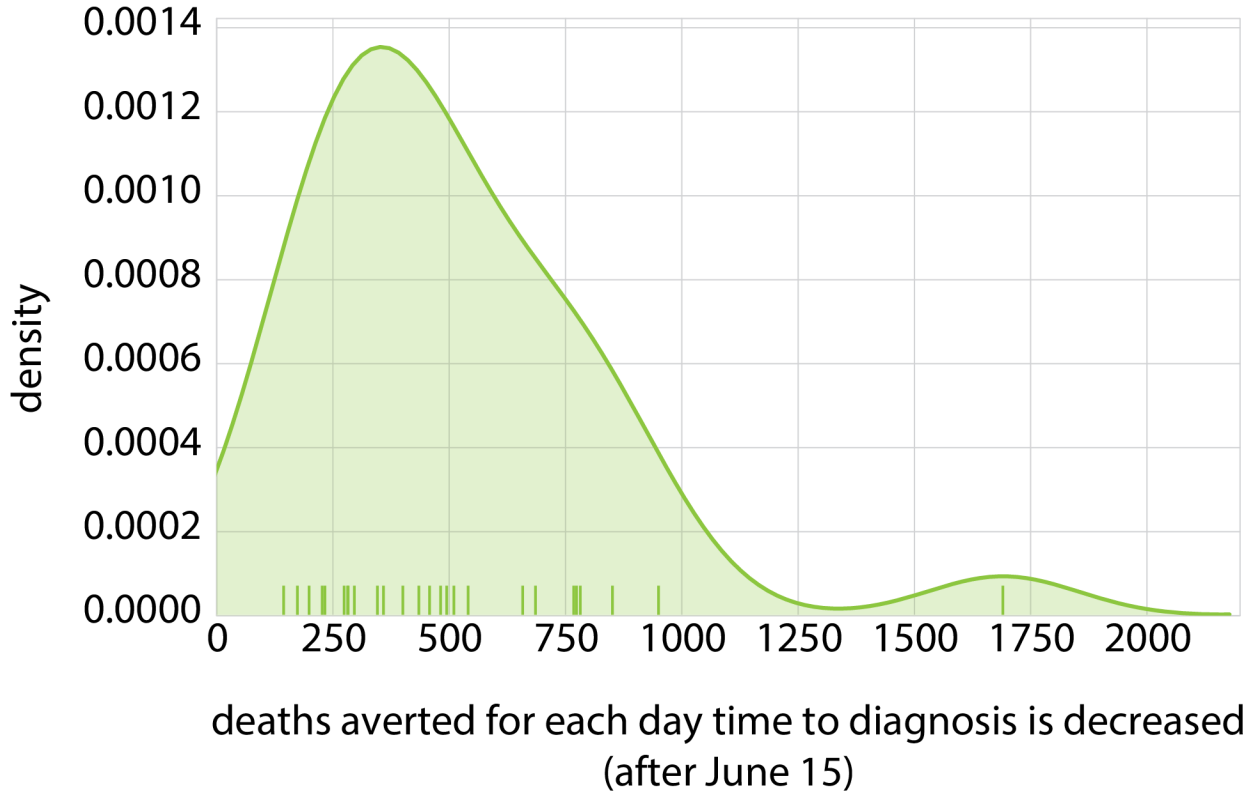

The later the intervention date, the fewer deaths can be averted by decreasing time to diagnosis

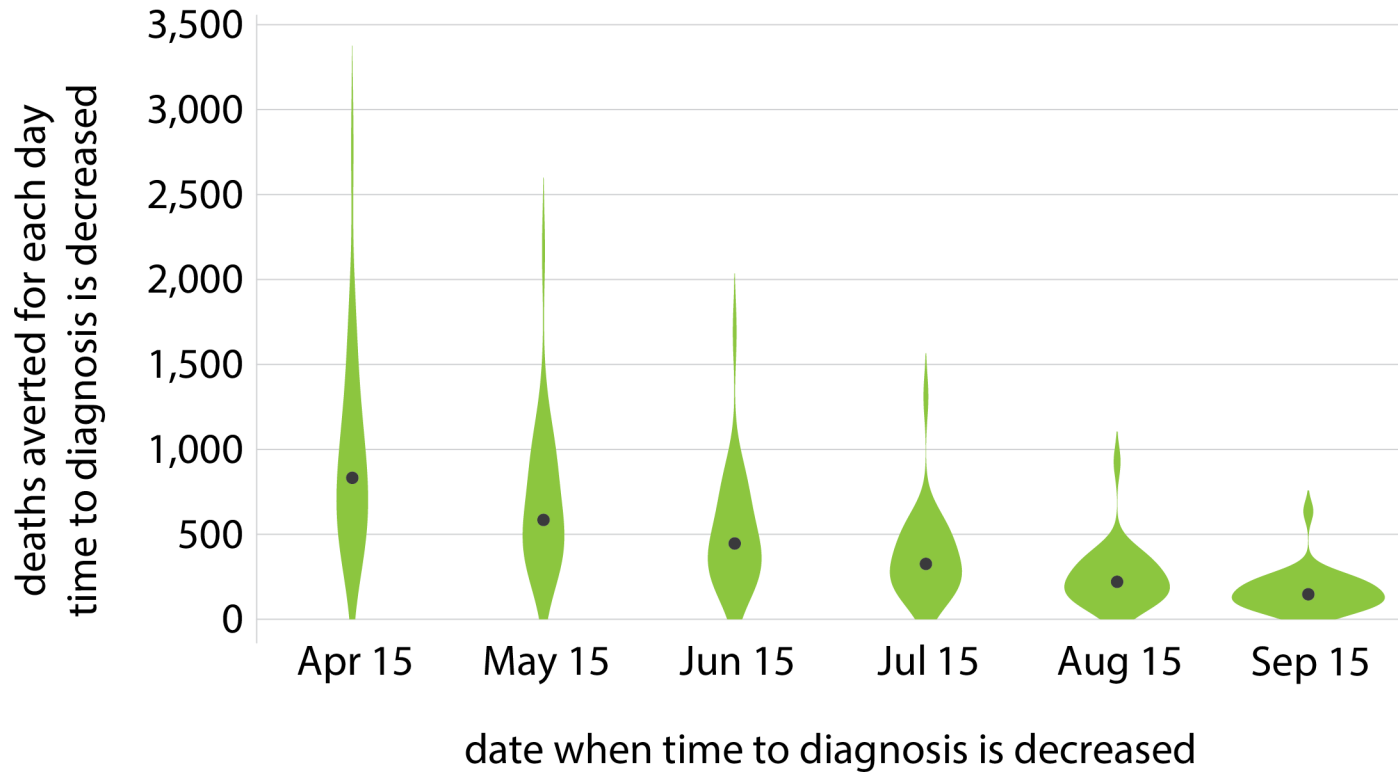

Varying the detection rates of mild infections shows higher effect of reducing time to diagnosis (steeper curve) at higher detection levels

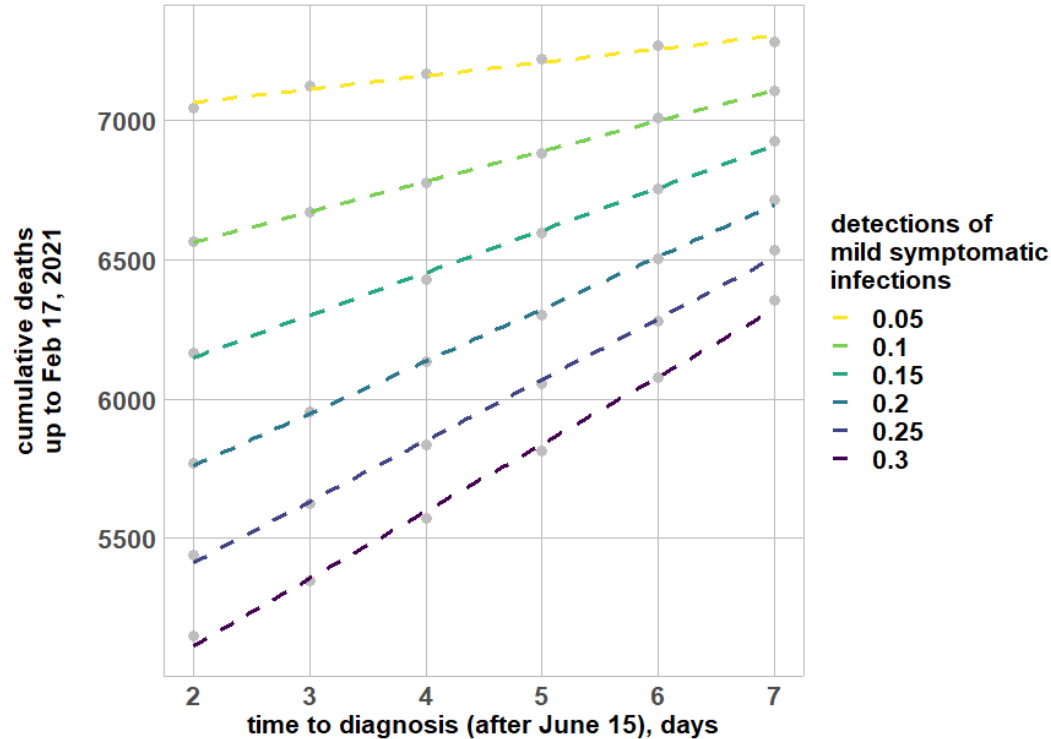

Preliminary conclusions

- Reducing time between onset of symptoms and notification of positive diagnosis could **potentially prevent hundreds of deaths** in Illinois
- Better access to testing, reduced turnaround time on test results, and more presumptive testing could reduce testing delay
- These interventions are more effective the sooner they are made
- **We expect to see even larger impact of reducing time to diagnosis if there is a rebound in transmission.**